

*Installation Guide  
for*



***AL800UL-ADA***  
*NAC Power Extender*



**Altronix**<sup>®</sup>

## ***AL800UL-ADA - ADA Compliant NAC Power Extender Installation Guide***

### ***Overview:***

The Altronix AL800UL-ADA is an extremely cost effective 8 amps voltage regulated remote power supply /battery charger. The AL800UL-ADA may be connected to any 12 or 24 volt Fire Alarm Control Panel (FACP). Primary applications include Notification Appliance Circuit (NAC) expansion (supports ADA requirements) and will provide auxiliary power to support system accessories. The unit delivers regulated and filtered 24 or 12 volt power via four (4) Class B, two (2) Class A or two (2) Class B and one (1) Class A Notification Appliance Circuits. Additionally, a separate 50mA auxiliary output with reset for four (4)-wire smoke detectors. The 8 amps rated supply current can be divided between the four (4) outputs for powering notification appliances. Each output is rated at 2 amps max., and can be independently programmed for Steady, Temporal Code 3 or \*Strobe Synchronization. All outputs may be programmed for Input to Output Follower Mode (output will follow input. i.e. March Time Input, March Time Output). An individual output of 4 amps is achieved by paralleling 2 outputs. The AL800UL-ADA in non-alarm condition provides independent loop supervision for Class A and/or Class B FACP NAC circuits. In the event of a loop trouble the FACP will be notified via the AL800UL-ADA's steered input (input 1 or input 2). In addition, there are common trouble output terminals (NC, C, NO) which are used to indicate general loop/system trouble. A common trouble input is provided for optional NC (normally closed) devices to report trouble to the FACP. Two (2) FACP signaling outputs can be connected to AL800UL-ADA's inputs. These inputs can then be directed to control supervision and power delivery to any combination of the four (4) outputs.

### ***Specifications:***

- UL Listed (UL864)
  - CSFM - California State Fire Marshal Approved
  - MEA - NYC Department of Buildings Approved
  - NFPA 72 Compliant.
  - Input 115VAC/60 Hz, 3.2 amps
  - Field selectable 24VDC or 12VDC voltage regulated power limited outputs.
  - 24VDC or 12VDC rated @ 8 amps max.
  - Typical 8.6 mV output voltage ripple.
  - Separate 50mA auxiliary output with built-in and remote reset capability.
  - Two (2) outputs may be paralleled for more power on an indicating circuit.
  - Two (2) Class A or two (2) Class B FACP inputs.
  - Two (2) NC dry contact trigger inputs
  - Programmable supervised indicating circuit outputs:  
Four (4) Class B or Two (2) Class A or One (1) Class A and Two (2) Class B.
  - Temporal Code 3, \*Strobe Sync Mode, Steady Mode, Input to Output Follower Mode (maintains synchronization of notification appliances circuit)
  - March Time
  - Compatible with 12 or 24VDC fire panels.
  - Filtered and electronically regulated output.
  - Output loop supervision steered to input 1 or input 2.
  - Common trouble input and output.
  - Ground fault detection.
  - Built-in charger for sealed lead acid or gel type batteries.
  - Automatic switchover to stand-by battery when AC Fails.
  - Zero voltage drop when switching over to battery backup.
  - Thermal and short circuit protection with auto reset.
  - Circuit breaker battery protection.
  - Input and output status LED indicators.
  - AC fail supervision (form "C" contact, 1 amp 28VDC or 115VAC).  
Factory set for 1 minute with optional 6 hour delay setting (field selectable).
  - Battery presence and low battery supervision (form "C" contact, 1 amp / 28VDC or 115VAC).
  - Unit includes power supply, red enclosure, cam lock, open frame transformer and battery leads.
- Enclosure dimensions: 15.5"H x 12"W x 4.5"D



\*See pg. 3

**Power Supply Specifications:**

<b>AC Input:</b>	115VAC / 3.2 amps @ 60Hz
<b>Output:</b>	12 - 24VDC. Maximum 2.0 amps per output. Total of 8 amps in Alarm Condition.
<b>Battery:</b>	For 12VDC operation use a 12VDC / 12AH battery For 24VDC operation use two (2) 12VDC / 12AH batteries connected in series
<b>Stand-by Current:</b>	75mA
<b>EOL Resistor: (end of line)</b>	2.2K (2200 ohm)

**Stand-by Specifications:**

Stand-by Batteries	Stand-by Time	Alarm Output Total Amps/Minutes	Aux Output Current
24VDC/12AH (use two (2) 12VDC batteries in series)	24 Hours	8 Amps/15 Minutes	50mA
	60 Hours	8 Amps/5 Minutes	-
12VDC/12AH	24 Hours	8 Amps/15 Minutes	50mA
	60 Hours	8 Amps/5 Minutes	-

**Installation Instructions:**

The AL800UL-ADA should be installed in accordance with article 760 of The National Electrical Code or NFPA 72 as well as all applicable Local Codes.

1. Mount the AL800UL-ADA in a desired location. It is recommended to first review the following tables for screw terminals, switch selection and LED status indications. This will greatly facilitate installation hook-up.

**Carefully review:**

- Power Supply Specifications* (pg. 2)
- Typical Application Diagrams* (pg. 5)
- Terminal Identification Table* (pg. 4)
- Output Programming Selection Table* (pg. 3)
- LED Status Indication Table* (pg. 3)

2. Connect the black and white transformer leads of AL800UL-ADA to a separate unswitched AC circuit (115VAC, 50/60Hz) dedicated to the Fire Alarm System (Fig. 1).
3. Set switch SW1 on Power Supply Board for desired output voltage. Open for 24VDC (factory set), Close for 12VDC.  
**Note:** It is good operating practice to measure and verify output voltage before connecting devices to ensure proper operation of equipment.
4. Connect battery to terminals marked [+ BAT -] on the Power Supply Board (battery leads included). Use two (2) 12VDC batteries connected in series for 24VDC operation.
5. Set output selection switches marked (OUT1 through OUT4) to follow corresponding input (IN1 & IN2) and desired output signal type (Temporal Code 3, Strobe synchronization, Steady output or input to output synchronization) (see output programming selection table pg. 3).
6. Connect FACP output to desired AL800LGK logic board inputs and notification appliances to desired AL800LGK logic board outputs (see typical application diagrams pg. 6).
7. For connection of smoke detectors, digital dialer (see optional hookup diagram pg. 6).
8. To report a ground fault connect negative (-) terminal of the auxiliary output marked [-AUX] to earth ground.

**Fig. 1**

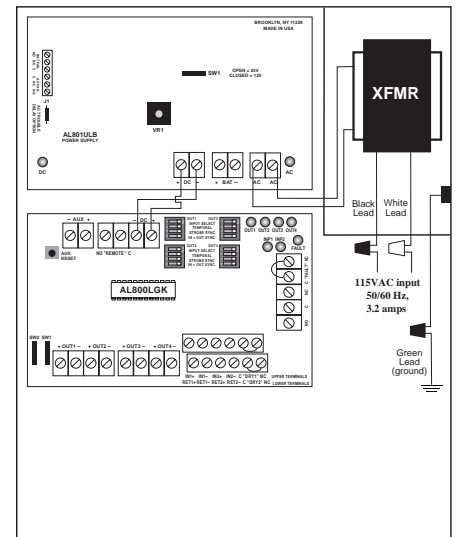

**General Information:**

- For all Class B hookups SW1 & SW2 on the AL800LGK logic board must be open.  
For all Class A hookups SW1 & SW2 on the AL800LGK logic board must be closed.
- AC Fail condition will report approximately one (1) minute after loss of AC. To delay report for 6 hours cut jumper J1 on the Power Supply Board (AC trouble output delay option). If this mode is selected the Power Supply Board must be reset by removing all power to it for 30 seconds.
- Low battery condition will report at approximately 21VDC (24VDC output setting)

- or approximately 10.5VDC (12VDC output setting).
- Battery presence detection will report approximately 5 minutes after battery remains undetected (missing or removed).
  - It is recommended (not required) to control visual notification appliances (strobes) via input 1 (IN1) and audible notification appliances (horns) via input 2 (IN2). This allows audible notification appliances (horns) to be silenced while visual notification appliances (strobes) continue to operate.

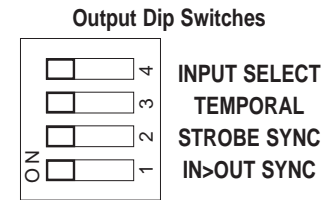

*(AL800LGK Board)*

**Output Programming Selection Table:**

*Outputs must be programmed independently (OUT1 - OUT4)*

Function	Switch Positions		Descriptions
	ON	OFF	
Input/Output Select	4		Output will be controlled by input 1 (IN1).
		4	Output will be controlled by input 2 (IN2).
Temporal Code 3 Mode	3		Enables Temporal Code 3 signal generation output. This mode will accept a steady or a pulsing input.
		3	Disables Temporal Code 3 signal generation output
Input to Output Follower Mode	1		Output follows signal it receives from the corresponding input (i.e. FACP Sync module - maintains synchronization of notification appliance circuit.
		1	Disables Input to Output Follower Mode.
Steady Mode		1, 2, 3	A steady output signal will be generated. This mode will accept steady or pulsing input.
March Time (60 beats per minute)	2, 3		Enables a March Time output which will sound 60 beats per minute. This mode will accept a steady or pulsing input.
Strobe Sync Mode 1	2		Enables Strobe synchronization mode 1 (50 ms pulse every 1 second). Will accept a steady or pulsing input. (Gentex®)
*Strobe Sync Mode 2	1, 2, 3		Enables Strobe synchronization mode 2 (30 ms pulse every .95 second). Will accept a steady or pulsing input. (System Sensor®)
Strobe Sync Mode 3	1, 2		Enables Strobe synchronization mode 3 (40 ms pulse every 1 second). Will accept a steady or pulsing input. (Faraday)
Strobe Sync Mode 4	1, 3		Enables Strobe synchronization mode 4 (60 ms pulse every 1 second). Will accept a steady or pulsing input. (Amseco)

**\*Strobe Sync Mode Information**

Synchronization is defined as the simultaneous flash of all visual signals in a given field of view.

**LED Status Indication Table:**

LED	OFF	ON	BLINKING
Out 1	Normal	Alarm Condition	Trouble Condition
Out 2	Normal	Alarm Condition	Trouble Condition
Out 3	Normal	Alarm Condition	Trouble Condition
Out 4	Normal	Alarm Condition	Trouble Condition
Input 1	Normal	Alarm Condition	Trouble Condition
Input 2	Normal	Alarm Condition	Trouble Condition
Fault	Normal	System Trouble	N/A
AC	AC Loss	AC present	N/A
DC	No DC Output	DC present	N/A

**Terminal Identification Table:  
AL800LGK Logic Board**

<b>Terminal Legend</b>	<b>Function/Description</b>
IN1+, IN1- IN2+, IN2-	These terminals connect to the 12 or 24VDC FACP notification appliance circuit outputs. (Class A or Class B) Input trigger voltage is 9-30VDC @ 5mA min. Terminal polarity is shown in alarm condition. During an alarm condition these inputs will cause the selected outputs chosen to drive notification appliances. The designated outputs are set by output switches OUT1 through OUT4 (see Output Programming Selection Table pg. 4). A trouble condition on an output loop will cause the corresponding input to trip the FACP by opening the FACP loop. An alarm condition will always override trouble to drive notification appliances.
RET1+, RET1- RET2+, RET2-	For Class A hookups these terminal pairs return to FACP NAC1 and/or NAC2. For Class B hookups the FACP EOL resistor from the NAC1 and/or NAC2 outputs are terminated at these terminals. Optionally, other notification appliances or additional signaling circuit power supplies may be connected to these terminals. If this option is chosen the EOL resistor must be terminated at the last device.
C “DRY1” N.C. C “DRY2” N.C. (Dry input trigger)	An open across these terminal pairs will cause the selected outputs chosen to drive notification appliances. The designated outputs are set by output switches OUT1 through OUT4 (see Output Programming Selection Table pg. 4). Note these inputs are unidirectional and will not report a trouble condition to the FACP.
+ OUT1 - + OUT2 - + OUT3 - + OUT4 -	Notification appliances are connected to these outputs (see typical application diagrams pg. 6). Each power limited output will supply 2 amps. Two (2) outputs may be connected in parallel for a maximum NAC output capability of 4 amps. Total supply current is 8 amps. Outputs are controlled by designated input 1 (IN1) or input 2 (IN2) (see Output Programming Selection Table pg. 4).
C “FAULT” N.C. (Common trouble input)	An open circuit across this pair of terminals will cause IN1 and IN2 to simultaneously signal a trouble condition back to the FACP (Typically used to report AC or BAT Fail).
N.C., C, N.O. (Common trouble output)	These are dry contact trouble outputs that follow any general loop/system trouble conditions. (Typically used to trigger a digital communicator or other reporting device).
- AUX+	This separate 50mA auxiliary output is typically used to power 4-wire smoke detectors. It can be reset (voltage drops out) by pressing the momentary aux reset switch on the AL800LGK logic board or via the N.O. “REMOTE” C terminals. (fig. 4 pg. 6)
N.O. C “REMOTE”	A momentary dry contact closure across these terminals interrupts the - AUX+ power output to reset 4-wire smoke detectors

**Power Supply Board**

<b>Terminal Legend</b>	<b>Function/Description</b>
AC FAIL C, N.C., N.O.	Form “C” dry contacts used to signal the loss of AC, with AC present terminals N.O. and C are open, N.C. and C are closed. When loss of AC occurs terminals N.O. and C close, N.C. and C are open.
BAT FAIL N.O., N.C., C	Form “C” dry contacts used to signal low battery voltage or loss of battery voltage. Under normal conditions terminals N.O. and C are open, N.C. and C are closed. During a trouble condition terminals N.O. and C are closed, and N.C. and C are open.
BAT+, BAT-	Stand-by battery input (leads provided). Use two (2) 12VDC batteries wired in series for 24VDC operation.

## Typical Application Diagrams:

Fig. 2

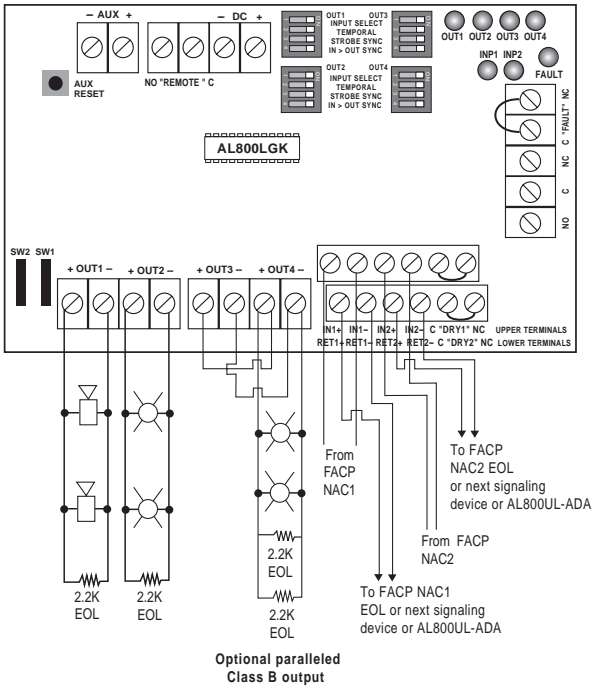

### Class B hookup:

- Switches SW1 & SW2 on AL800LGK logic board must be in the open position.
- It is recommended (not required) to control visual notification appliances (strobes) via Input 1 (IN1) & to control audible notification appliances (horns) via Input 2 (IN2). This facilitates the ability to silence audible notification appliances (horns) independently of visual notification appliances (strobes) during certain operations.

**Note:** If common trouble (C “FAULT” N.C.) or dry contact (C “DRY1” N.C. & C “DRY2” N.C.) input options are not used, these terminal pairs must be shorted (connect jumper) to remain inactive. For optional hookups (see Fig. 4 pg. 7).

Two outputs may be connected in parallel for a maximum NAC output capability of 4 amps. When paralleling two (2) outputs, bridge (pos +) to (pos +) and (neg -) to (neg -). Both of the corresponding output switches must be set to follow the same input. Install two (2) 2.2K ohm EOL resistors in parallel across the last notification appliance.

Paralleled output circuit configuration is non-power limited.

Fig. 3

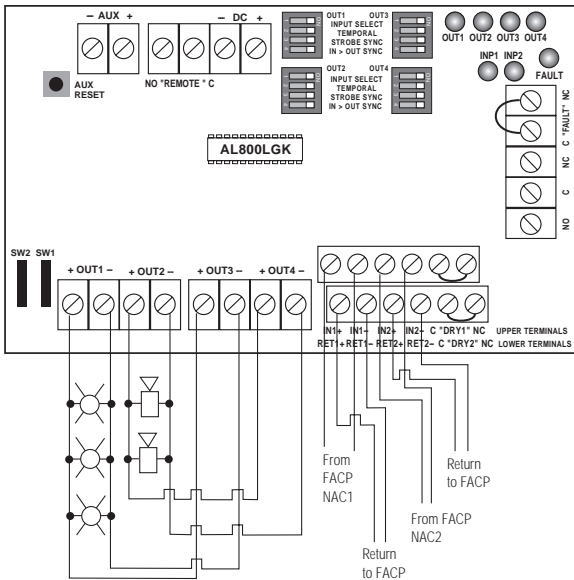

### Class A hookup:

- Switches SW1 & SW2 on AL800LGK logic board must be in the closed position for proper termination of NAC. Loop 1 starts on Output 1 and terminates on Output 3. Loop 2 starts on Output 2 and terminates on Output 4. Both of the corresponding output switches must be set to follow the same input.
- It is recommended (not required) to control visual notification appliances (strobes) via Input 1 (IN1) & to control audible notification appliances (horns) via Input 2 (IN2). This facilitates the ability to silence audible notification appliances (horns) independently of visual notification appliances (strobes) during certain operations.

**Note:** If common trouble (C “FAULT” N.C.) or dry contact (C “DRY1” N.C. & C “DRY2” N.C.) input options are not used, these terminal pairs must be shorted (connect jumper) to remain inactive. For optional hookups (Fig. 4 pg. 6).

**Legend**

	Horn		Strobes		Horn Strobes
--	------	--	---------	--	--------------

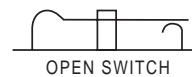

Switch Detail

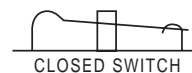

## Optional Hookup Diagram:

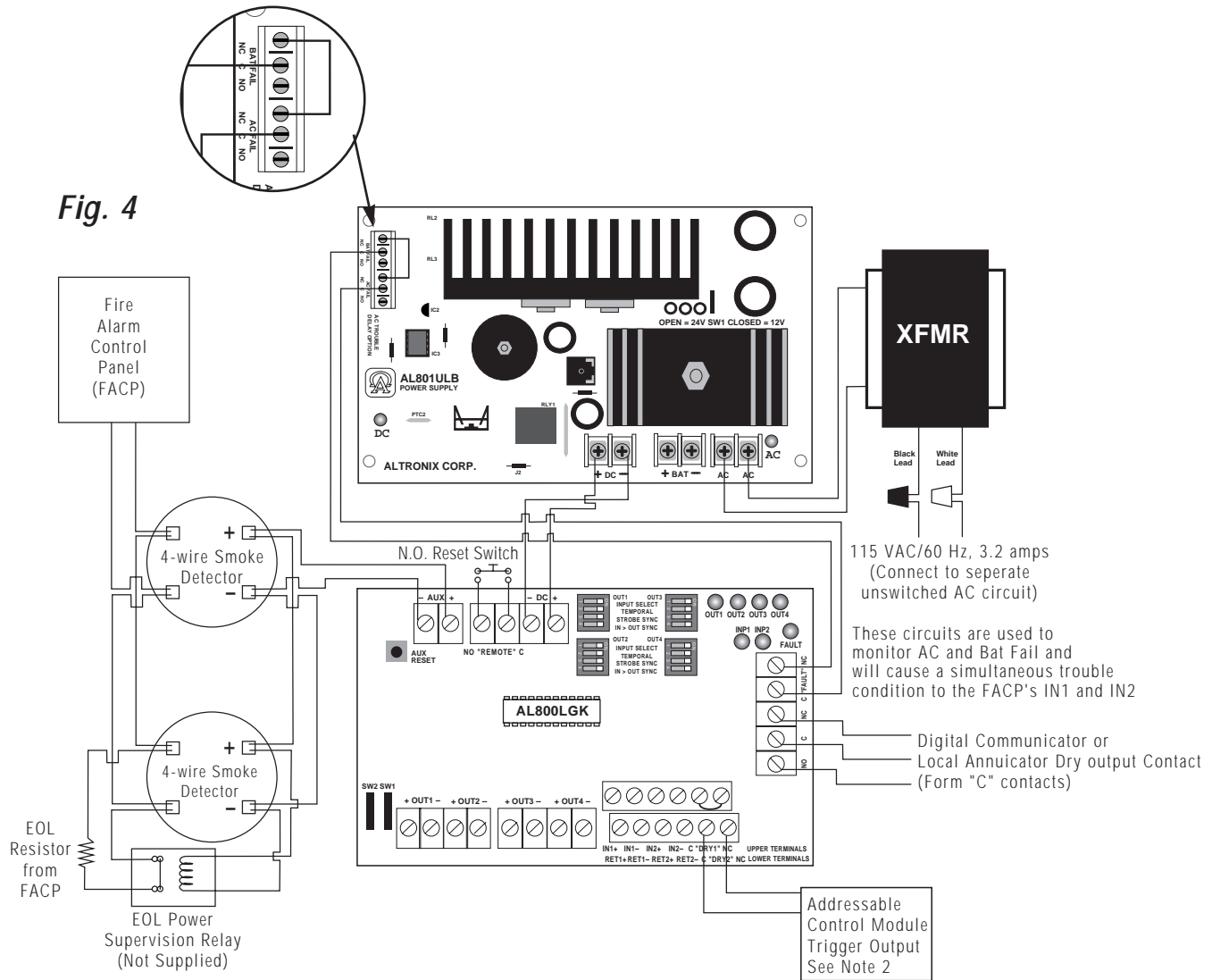

### Optional hookups:

- 1- Battery and AC monitoring: AC or Battery Fail condition will cause the common trouble input (C "FAULT" N.C.) to report back to the FACP via input 1 and input 2. The common trouble input may also be used for other optional supervisory monitoring.

To report AC and Battery Trouble connect the battery and AC Fail relay output shown in Fig. 4 above to the common trouble input.

- 2- Dry contact input (IN1DRY, IN2DRY) (IN1DRY, IN2DRY) can be used to alarm output from an addressable module (these inputs are unidirectional and cannot report back to trigger module).

**Note:** If common trouble (C "FAULT" N.C.) or dry contact (C "DRY1" N.C. & C "DRY2" N.C.) input options are not used, these terminal pairs must be shorted (connect jumper) to remain inactive.

- 3- Auxiliary output (-AUX+) provides 12VDC or 24VDC at 50mA max. The output voltage is determined by the setting of switch marked SW1 on the Power Supply Board. It can be reset by a momentary closure across terminals (N.O. REMOTE C) or by pressing AUX RESET button on the AL800LGK logic board.

Typical Sync Module hookups

Fig. 5: Synchronization using one (1) synchronization module with four (4) outputs.

Note: When using this configuration you must enable the Input to Output Follower Mode (Dip Switch 1 ON) and disable the Strobe Sync Mode (Dip Switch 2 OFF).

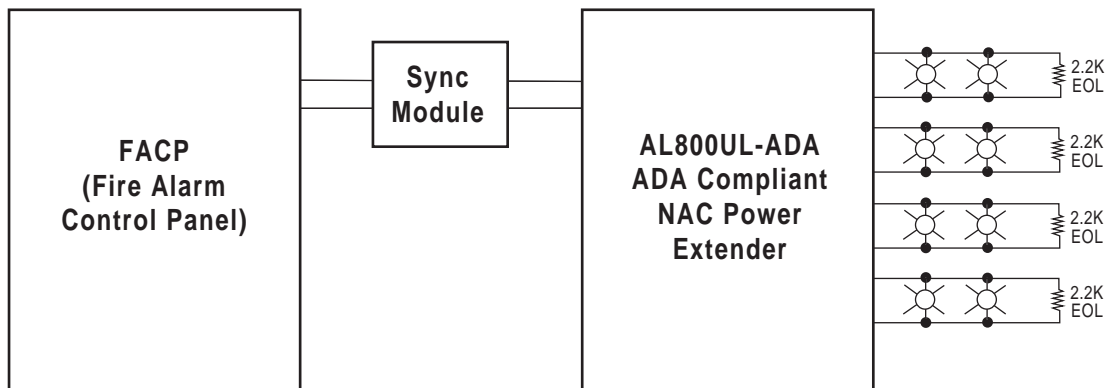
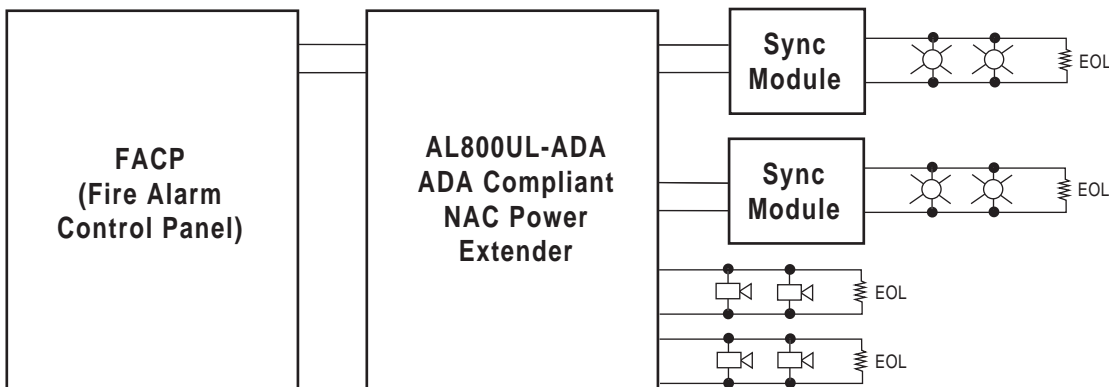





Fig. 6: Synchronization using multiple synchronization modules.

Note: When using this configuration you must disable the Input to Output Follower Mode (Dip Switch 1 OFF) and disable the Strobe Sync Mode (Dip Switch 2 OFF).



<b>Legend</b>	 Horn	 Strobes	 Horn Strobes
---------------	--	---	--



**Typical Application Diagram for Connecting Horn/Strobes with Independent Control of Horns and**

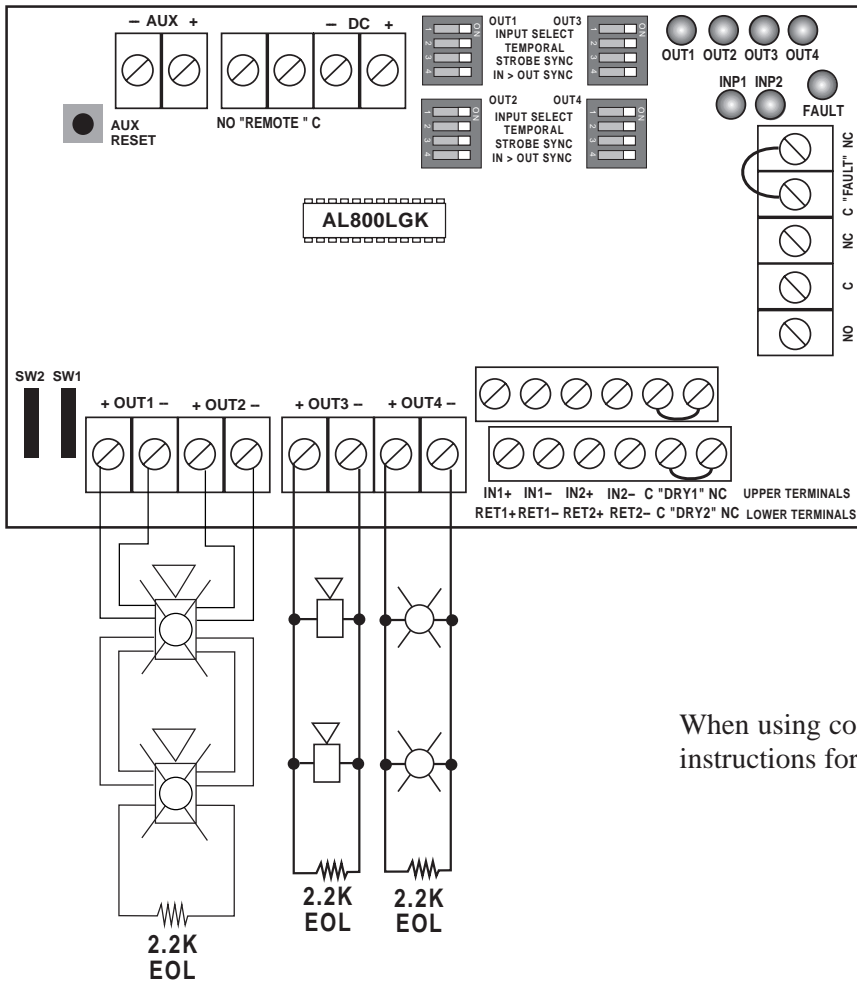

When using combination horn/strobes. Follow manufacturer's instructions for powering horns and strobes independently.

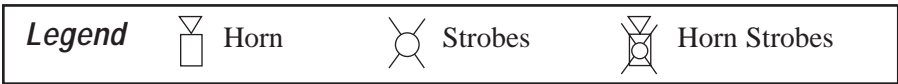

***Maintenance:***

Unit should be tested at least once a year for the proper operation as follows:

Output Voltage Test: Under normal load conditions, the DC output voltage should be checked for proper voltage level (see power supply output specifications chart).

Battery Test: Under normal load conditions check that the battery is fully charged. Check specified voltage both at battery terminal and at the board terminals marked [- BAT +] to insure there is no break in the battery connection wires.

**Note:** Maximum charging current is 700mA.

**Note:** Expected battery life is 5 years, however it is recommended changing batteries in 4 years or less if needed.

**Enclosure Dimensions:**  
15.5"H x 12"W x 4.5"D

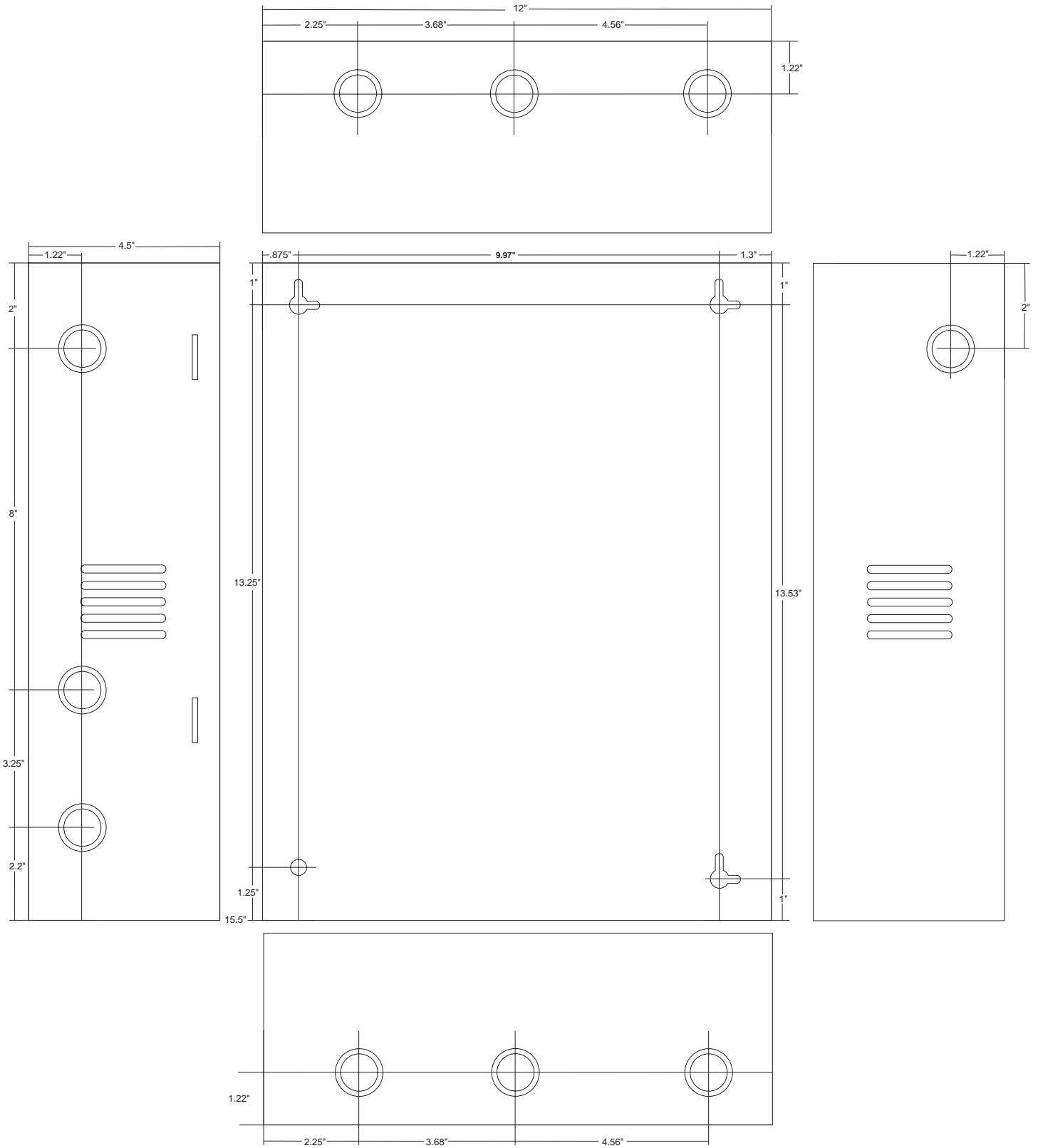

*Notes:*



---

Altronix Corp.  
140 58th Street, Brooklyn, New York 11220 USA, 718-567-8181, fax: 718-567-9056  
web site: [www.altronix.com](http://www.altronix.com), e-mail: [info@altronix.com](mailto:info@altronix.com), Lifetime Warranty, Made in U.S.A.  
IIAL800ULADA - Rev. 062600